

JG Speedfit®

The Push-fit Solution for Plumbing and Heating Systems



THE
UNDERFLOOR
HEATING
MANUFACTURERS' ASSOCIATION

SINGLE ROOM UNDERFLOOR HEATING PACK INSTALLATION AND USER GUIDE

IDEAL FOR CONSERVATORIES AND EXTENSIONS

JGUFHPACK20 - FOR UP TO 20SQM
JGUFHPACK30 - FOR UP TO 30SQM

May 2010

THE JG SPEEDFIT UNDERFLOOR HEATING PACKS

- **Ideal for conservatories and extensions**
 - **Quick and easy to install**
 - **Stand alone system**
 - **Pre assembled and pre wired**
 - **Suitable for tiled, timber or carpeted floor coverings**



BOTH PACKS CONTAIN :-

Control Unit, which is pre assembled and pre wired, has integral ballvalves to allow for isolation from the primary system, an adjustable blending valve to control the temperature of the water and a high quality 6 metre head circulating pump. An anti-vibration mounting bracket ensures silent operation. The unit can be plugged into any convenient electrical socket or spur.

Programmable Room Thermostat to give individual time and temperature control to the conservatory or room extension. An LCD display shows current and set temperatures. A simple menu makes for easy adjustment by the householder.

Speedfit Barrier Pipe, manufactured and Kitemarked to BS7291 Class S.



20SQM

THE 20SQM PACK CONTAINS



30SQM

THE 30SQM PACK CONTAINS



**THE PACKS ARE DESIGNED TO BE USED
IN SOLID FLOOR INSTALLATIONS**

READ THIS FIRST

The information contained in this publication is designed to assist with the trouble free installation of a Speedfit Single Room Underfloor Heating Pack.

Before installing or operating any part of the Speedfit System, please read through this Instruction Manual thoroughly. On completion of the installation, leave a copy with the householder for future reference.

It is the responsibility of the installer to ensure that equipment connected to the Speedfit System is suitable for the purpose for which it is used and installed in accordance with the manufacturer's instructions.

WARRANTIES

As a result of its long term programmes and rigorous quality standards John Guest Speedfit Limited offer a 25 year guarantee against the defects in materials or manufacturing of Speedfit Barrier Pipe manufactured by John Guest.

John Guest Underfloor Heating Products, which should be installed and maintained in accordance with our recommendations, carry a 2 year guarantee against defects in materials and manufacture.

John Guest Plumbing and Heating Products are for use with normal UK domestic plumbing and heating systems and supplied in accordance with our Conditions of Sale.

ELECTRICAL INSTALLATION

In accordance with current legislation, a competent and qualified person must complete all electrical work. JG Speedfit cannot be held responsible for damage to components, fixtures, fittings or injury caused by incorrect or faulty wiring.

PRE INSTALLATION CHECKS

To ensure suitability of the Heating Pack, please note the following

- Speedfit recommend that wherever possible, the Control Unit be connected to the primary flow and return and wired independently back to the boiler.
- The boiler serving the new system will need to have the ability to take the extra output of up to 3KW.
- The boiler needs to be compatible with the additional pump on the system.
- In areas of high heatloss such as conservatories, additional heating may be needed to obtain optimum comfort levels.
- Pack JGUFHPACK20 will serve a maximum area of 20m² and Pack JGUFHPACK30 will serve a maximum area of 30m²

For floor areas larger than 30m², Speedfit offer a range of underfloor heating products to cater for any size of project. For further information contact our Technical Help Desk 01895 425333.

SITE PREPARATION



The site for the underfloor heating system should be clean and level.

A layer of Speedfit Edge Strip should be fixed around the perimeter of the area. This will reduce heatloss and act as an expansion medium. The Strip should be fitted up to finished floor level, to be trimmed after the screed has cured.

The floor insulation can now be fitted. Tape up all joints to prevent cold bridges forming and screed getting beneath the insulation. The depth of insulation should comply with current Building Regulations, normally 60 - 70mm, Celotex or similar.

INSTALLATION OF CONTROL UNIT

The Underfloor Heating Control Unit should be fixed vertically with the mixing valve at either the top or the bottom, or horizontally with the electrical connection box uppermost.

Provision should be made to vent air to protect the pump from cavitation.

The Unit should NOT be floor mounted or in any other position that has the pump shaft vertical.

The Unit's situation must allow adequate clearance and accessibility for pipework and maintenance.

Locate the Control Unit on the wall and mark the hole fixing positions through the bracket.

Take care to protect the electrical equipment and cables.

Drill the holes using a 8mm masonry drill, plug the walls and secure the unit to the wall using the screws provided.

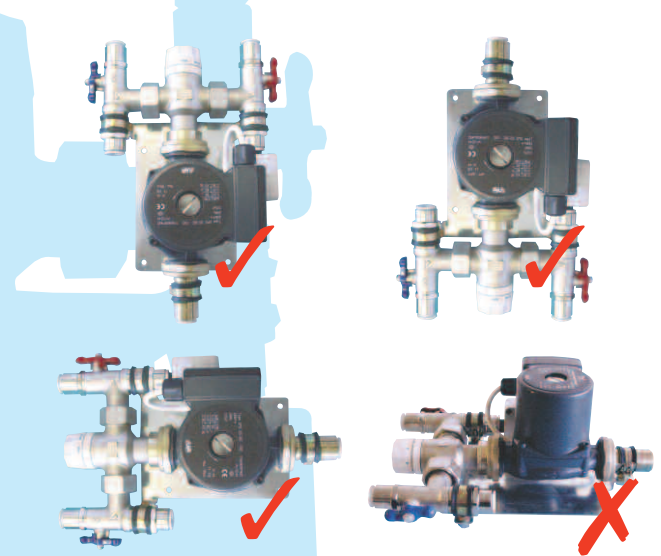

The Blending Valve on the Control Unit controls the temperature of the water in the underfloor heating loop. Temperature can be adjusted to suit the resistance of the floor to heat transfer.

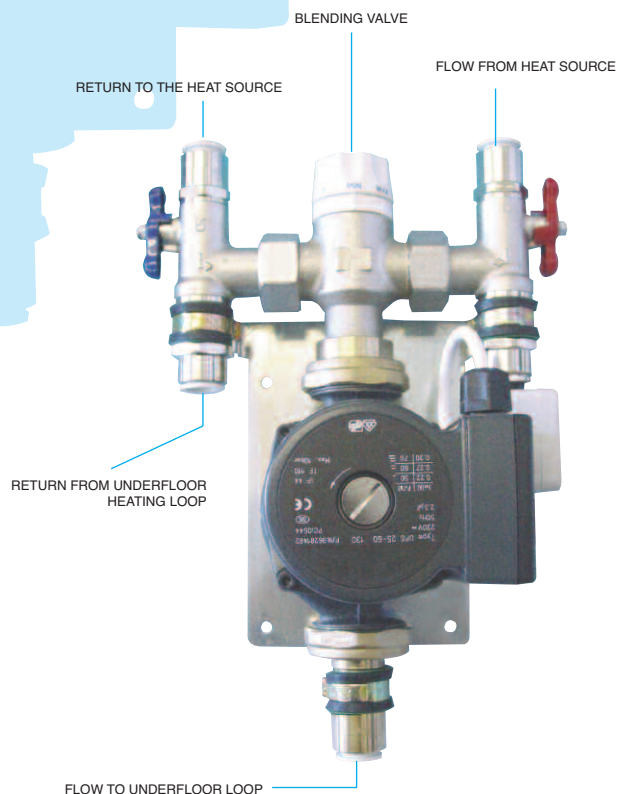

TYPICAL PIPEWORK CONNECTIONS

Speedfit recommend that wherever possible, the Control Unit is connected to the primary flow and return.

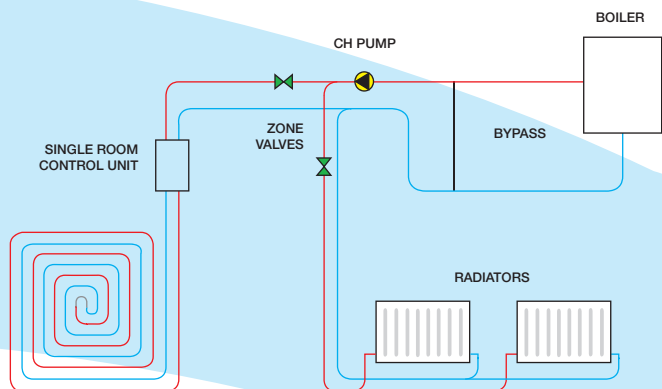

PRESSURE TESTING

The underfloor heating pipework should be pressure tested before the system is connected to the primary circuit and before screeding.

This is done by connecting the pressure tester via a piece of pipe to the red ballvalve and connecting a hose from the cold mains to the blue ballvalve.

Fully open both valves and fill the system, to purge all traces of air, until water is entering the pressure tester.

Turn the blue ballvalve off and disconnect the hose between the blue ballvalve and the mains. Using the pressure tester, pressurise the system to 2 Bar for 10 minutes and then 6 bar for 10 minutes.

The test to 6 Bar is because the pump is connected.

After testing, the system should remain pressurised at 6 Bar throughout the screeding and curing process. This is in accordance with BS EN1264 Part 4.

SCREEDING

The screed should be laid as soon as possible after the pressure test.

The system should be left pressurised during the screeding process. The screed must be laid so that it is in good contact with the pipes with no air pockets.

Traditional sand and cement screed is normally 65-75mm thick. It should be allowed to dry naturally in line with the requirements of the screed manufacturer's instructions and British Standards.

Special low thickness screeds are available and screed manufacturers will be able to advise on their use with underfloor heating.

Manufacturers' screed drying times will vary but under no circumstances should the underfloor heating system be used to speed up the drying process as it may damage the screed.

OPERATING PRINCIPLES

The Speedfit Control Unit which can be plugged into a convenient electrical socket or spur, will operate automatically when the primary heating circuit is on and the water temperature flowing through it has reached 40°C. The pump will continue to run until the temperature of water flowing through it from the heating circuit falls to approximately 30°C.

The blending valve will maintain the temperature of the underfloor heating circuit by blending flow from the boiler with the cooler return flow from the underfloor heating circuit.

If connected to an existing radiator circuit, the pump will be unable to operate independently, only able to obtain hot water when the radiator system is on.

BLENDING VALVE SETTINGS

The thermostatic blending valve has a temperature range of between 35°C and 60°C.

| | |
|-----|------|
| MIN | 35°C |
| 1 | 40°C |
| 2 | 44°C |
| 3 | 48°C |
| 4 | 50°C |
| 5 | 54°C |
| 6 | 58°C |
| MAX | 60°C |

After the screed drying process, the blending valve should be adjusted to suit comfort levels and the floor covering. For screeded floors the temperature level will normally be set between 44°C and 58°C.

To achieve comfort levels the maximum floor surface temperature will normally not be required to exceed 29°C (35°C in bathrooms).

Timber floor finishes such as laminated products may suffer from excessive material shrinkage if the floor surface temperature exceeds 27°C.

FOR A CONTROL UNIT PIPED BACK TO A PRIMARY CIRCUIT - 2 PORT VALVE CONTROLS THE BOILER

All wiring should be undertaken by a qualified electrician and conform to IEE Regulations. To comply with the regulations, the pump on the control unit is provided with an earth connection via the connection box.

Connect the control unit to a mains fed spur fused at 3 amps.

The method of control, which provides independent control of the boiler, is to use a Programmable Room Thermostat wired to a zone valve, fitted to a dedicated flow and return to the room pack. The zone valve will be used to turn the boiler on and off as per conventional central heating practice i.e. the switch live on the Programmable Room Thermostat is connected to a permanent live. The switched live from the Programmable Room Thermostat is connected to the switched live (brown) of the zone valve. This removes the need to alter the internal wiring on the Room Pack.

For further information, please contact the Speedfit Technical Helpdesk 01895 425333.

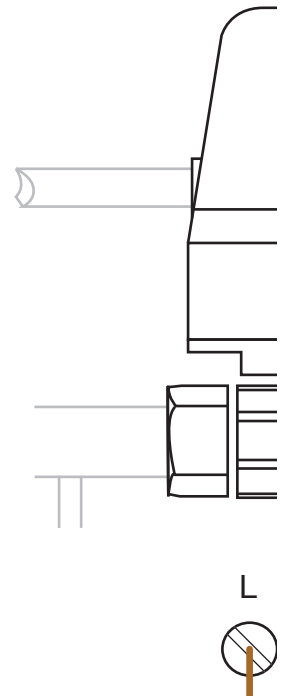
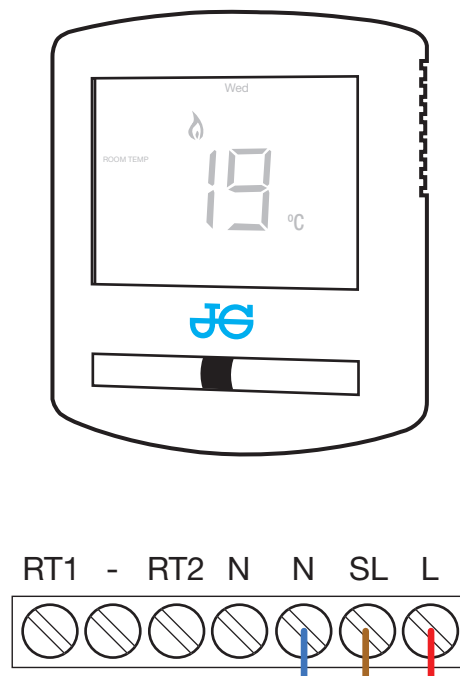

John Guest Speedfit Limited

Horton Road, West Drayton, Middlesex UB7 8JL, England.
Tel: 01895 449233 Fax: 01895 420321. www.speedfit.co.uk
Technical Help Desk: 01895 425333

JG, John Guest® and Speedfit® are registered trademarks of John Guest International Limited © Copyright 2010.

The company has a policy of continuous research and development and reserves the right to amend without notice the specification and design of all products illustrated in this catalogue. John Guest Speedfit reserve the right to change the colour and shape of products. Photographs are for illustration purposes only.

Subject to our Terms and Conditions of Sale available on request.

Z2105/239/05/10